

Battery Pack

SB-920P

本品は、出荷される国や地域により仕様等が異なることがあります。
 ※日本向け製品については、日本語で記載しています。
 英語などその他の言語で記載されている内容は、日本以外に出荷される製品の説明です。

Some specifications of this product may differ depending on the destination country or region. Therefore descriptions in the Japanese manual and English and other language manuals may also differ.

General

The SB-920P battery pack is a rechargeable battery for a CSM-1000 series bedside monitor.

Installation must be performed by qualified personnel.

Contact your Nihon Kohden representative for installation of the battery pack.













NOTE: Read this guide and the CSM-1000 series bedside monitor operator's manual for handling and safety of the battery pack.

Composition







Item	Supply Code/Code No.	Qty
SB-920P battery pack	X162	1
Heat radiation sheet	6114-931334	1
Start date label	6124-034393	1

Symbols

The following symbols are used with this battery pack. The description of each symbol is shown in the table below.

Symbol	Description	Symbol	Description
 (Background color: yellow)	General warning sign	 (Background color: blue)	Follow instructions for use.
	Attention, consult installation guide	 (Circle and slash: red)	Do not disassemble or modify the battery pack.
 (Circle and slash: red)	Keep away from fire.	 (Circle and slash: red)	Do not short-circuit the battery pack.
 (Circle and slash: red)	Keep away from water.	 (Circle and slash: red)	Do not give impact to the battery pack.
	This way up		Keep away from rain
	Fragile		Stacking limit by number ("n" is the limiting number)

0604-911861G

Symbol	Description	Symbol	Description
	Medical device The MD symbol is applied in accordance with European Union legislation.		Products marked with this symbol comply with an environmental protection use period of 10 years according to the SJ/T11364 "Marking for the Restricted Use of Hazardous Substances in Electronic and Electrical Products" of the People's Republic of China Electronic Industry Standard.
	The CE mark is a protected conformity mark of the European Union.		
	Products marked with this symbol require separate waste collection according to EU battery directive 2006/66/EC.		Bureau of Indian Standard mark (IS 16046-1 certified)
	Recycle		

Safety Information

 **WARNING** A warning alerts the user to possible injury or death associated with the use or misuse of the instrument.

Pay attention to all safety information in this manual type.

 **WARNING**

Do not do the following to the battery. It may cause leakage, overheating, explosion and fire.

- Short-circuit the + and – terminals on the battery.
- Put the battery into fire or heat the battery.
- Disassemble or modify the battery.
- Give strong impact to or deform the battery.
- Use the battery on unspecified instruments.
- Charge the battery on unspecified instruments.
- Install the battery with the wrong polarity
- Immerse the battery in liquid or get it wet.

 **WARNING**

If the liquid inside the battery contacts the eyes, mouth or skin, do not rub the eyes, mouth or skin. Wash with clean water and see a physician immediately.

Parts Descriptions

SB-920P Battery Pack

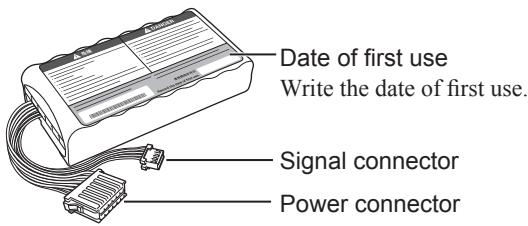

Heat Radiation Sheet

Both sides of the heat radiation sheet are covered with a protective film. Text is printed on the protective film covering the adhesive side of the heat radiation sheet.

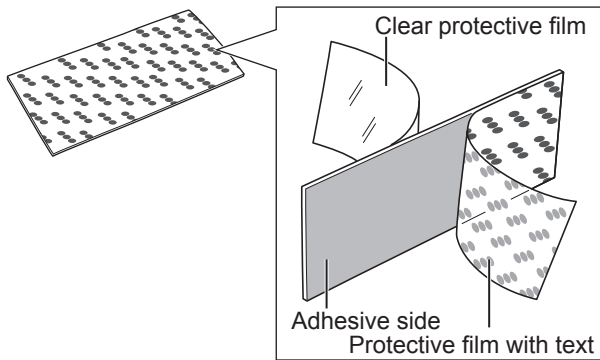

Start Date Label



Preparation

Write the date of first use of the battery pack on the battery pack and the provided start date label.

Tightening Torque

To prevent loosening, damage or deformation of screws, tighten the screw with the specified torque. The following table shows the rated value for each screw.

Nominal Diameter	Standard Torque (N•cm)	Tightening Torque (N•cm)
M2	18.6	15.7 to 20.6
M2.3	29.4	24.5 to 33.3
M2.6	41.2	36.3 to 47.0
M3	65.7	55.9 to 75.5
M4	152.9	130.3 to 174.4
M5	307.7	263.6 to 351.8
M6	521.4	445.9 to 595.8

Depending on where the screw is used, a different torque may be specified. Use the specified torque.

Installing the Battery Pack

NOTE: Turn off the CSM-1000 series bedside monitor and disconnect the power cord before starting installation.

1. Remove the heatsink cover.

The core unit has two different types.

When there is a top plate and top frame:

Remove the two screws to remove the heatsink cover.

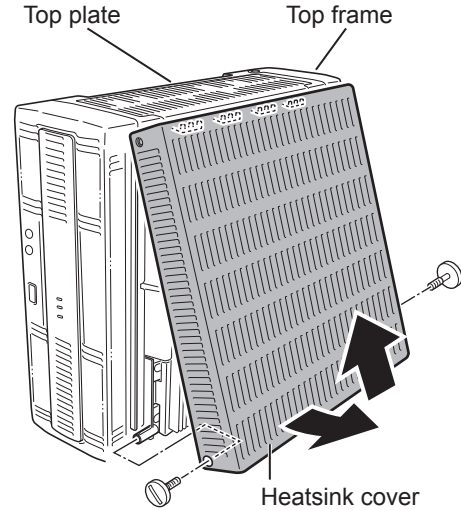

When there is a top cover:

Remove the four screws to remove the heatsink cover.

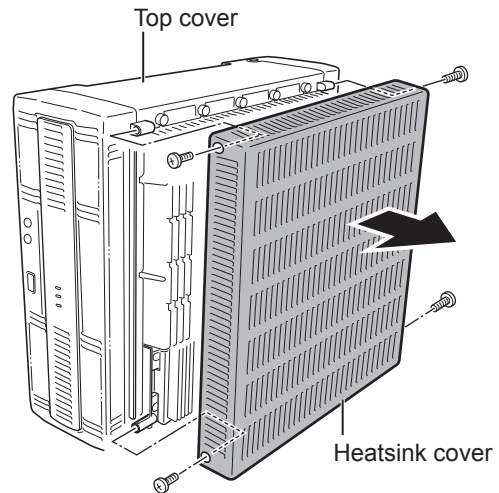

2. Remove the battery cover.

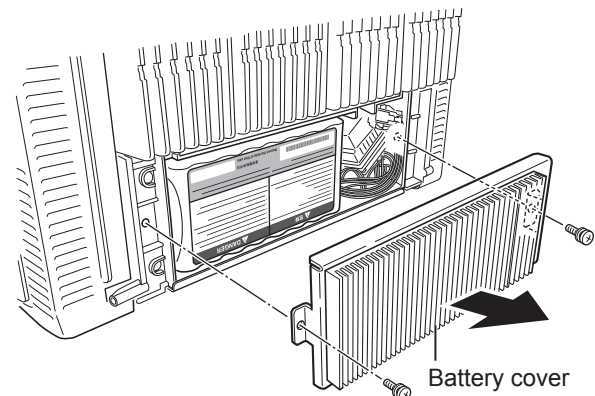

Proceed to step 5 if installing a battery pack for the first time.

3. Remove the heat radiation sheet from the battery cover.

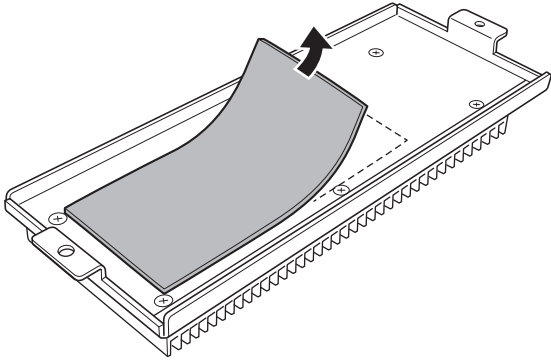

4. Remove the battery pack.

- 1) Remove the battery pack from the battery case.
- 2) Disconnect the signal connector by pressing in the latch indicated by the arrow.
- 3) Disconnect the power connector by pressing in the latches indicated by the arrows.

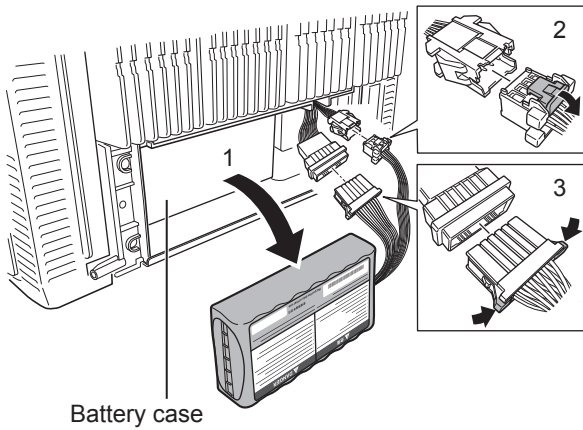

5. Attach the battery pack.

- 1) Connect the signal connector.
- 2) Connect the power connector.
- 3) Insert the battery pack into the battery case as shown.

NOTE: To keep the battery pack from getting hot, insert it as shown. If the battery pack is inserted in the wrong direction, it gets hot and the life of the battery pack may be reduced.

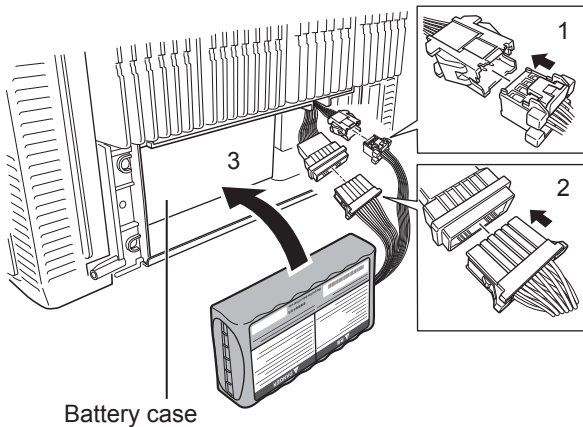

6. Attach the heat radiation sheet to the battery cover.

- 1) Remove the protective film (with text) from the adhesive side of the heat radiation sheet.
- 2) Attach the heat radiation sheet to the metal plate of the battery cover.
- 3) Remove the clear protective film.

NOTE

- Do not allow air bubbles to form when attaching the heat radiation sheet.
- Do not forget to remove the clear protective film.

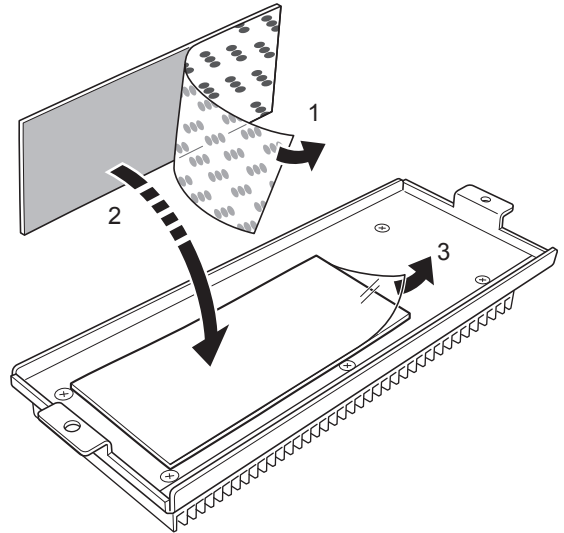

7. Attach the battery cover.

NOTE: Make sure that no cables get caught.

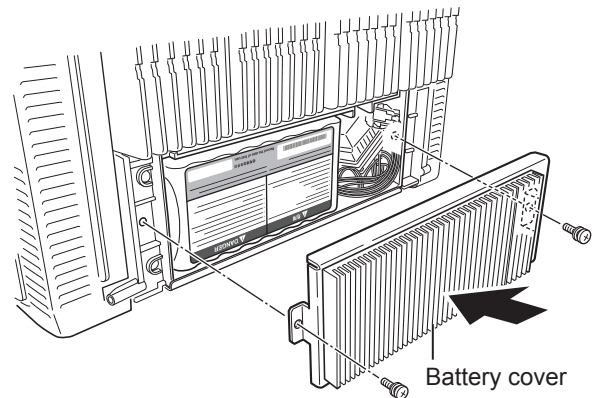

8. Attach the heatsink cover.

The core unit has two different types.

When there is a top plate and top frame:

Attach the heatsink cover and fix it with the two screws.

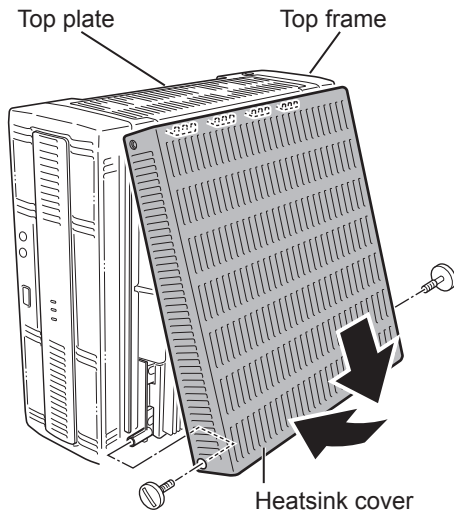

When there is a top cover:

Attach the heatsink cover and fix it with the four screws.

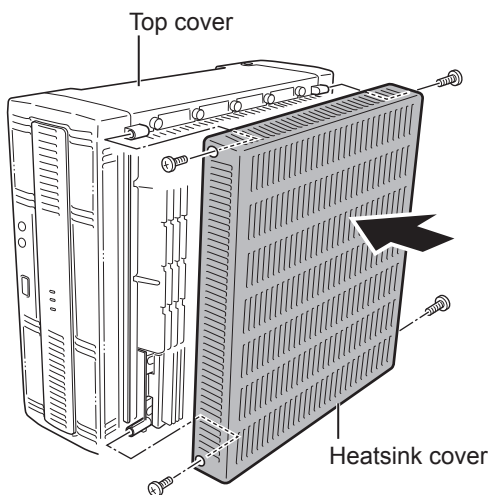

Attaching the Start Date Label

Attach the start date label on the bedside monitor. Replace the battery pack according to this date.

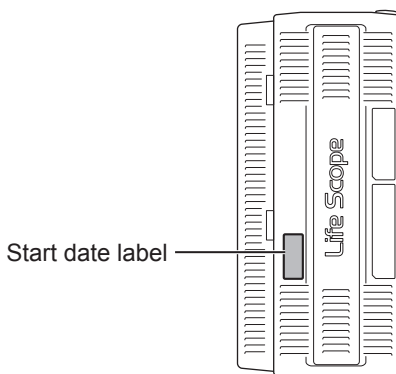

Checking the Operation

Refer to the CSM-1000 series bedside monitor service manual.

Charging Time/Operating Time

Refer to the CSM-1000 series bedside monitor operator's manual.

Replacing the Battery Pack

The battery may deteriorate depending on the usage condition, duration of use and storage environment. Periodically check the battery and replace it with a new one if an abnormality is found. When a "Battery Error" message appears, the battery might have a failure or be expired. Contact your Nihon Kohden representative.

The warranty period is one year from date of delivery.

Disposal of the Battery Pack

Before disposing of the battery pack, check with your local solid waste officials for details about recycling options or proper disposal in your area. The battery pack is recyclable. At the end of its useful life, under various state and local laws, it may be illegal to dispose of this battery into the municipal waste stream.

Specifications

Type of battery:	Nickel-metal hydride
Nominal voltage:	9.6 V
Nominal capacity:	2450 mAh
Rated capacity:	2250 mAh

Recommended Storage Environment

The storage temperature and humidity affect the lifetime of the battery pack. Store the battery pack in the following environment.

Temperature:	
1 month or less:	-20 to +60°C (-4 to +140°F)
3 months or less:	-20 to +45°C (-4 to +113°F)
12 months or less:	-20 to +35°C (-4 to +95°F)
Humidity:	20 to 85% RH (noncondensing)
Atmospheric pressure:	500 hPa to 1060 hPa

Note for users in the territory of the EEA and Switzerland:
Any serious incident that has occurred in relation to the device should be reported to the European Representative designated by the manufacturer and the Competent Authority of the Member State of the EEA and Switzerland in which the user and/or patient is established.

Copyright Notice

The entire contents of this manual are copyrighted by Nihon Kohden. All rights are reserved.

 Manufacturer
NIHON KOHDEN CORPORATION
1-31-4 Nishiochiai, Shinjuku-ku,
Tokyo 161-8560, Japan
Phone +81 3-5996-8041
<https://www.nihonkohden.com/>

 European Representative
NIHON KOHDEN EUROPE GmbH
Raiffeisenstrasse 10, D-61191 Rosbach, Germany
Phone +49 6003-827-0 Fax +49 6003-827-599

SHANGHAI KOHDEN MEDICAL ELECTRONIC INSTRUMENT CORP.
No. 567 Huancheng Bei Road
Shanghai Comprehensive Industrial Development Zone
Fengxian District, Shanghai 201401, China
Phone +86 21-5743-6998 Fax +86 21-5743-6939

NIHON KOHDEN AMERICA, INC.
15353 Barranca Parkway, Irvine, CA 92618, U.S.A.
Toll-free +1-800-325-0283
Phone +1 949-580-1555 Fax +1 949-580-1550

1st Edition: 19 Nov 2013
8th Edition: 26 Feb 2021
MUMG 347 [A] - CO-3730

